

# LONG BED KITS

**THIS PAGE 8' LONG BED**  
 1953-56 F-250 AND  
 1956-F-100 LONG BED

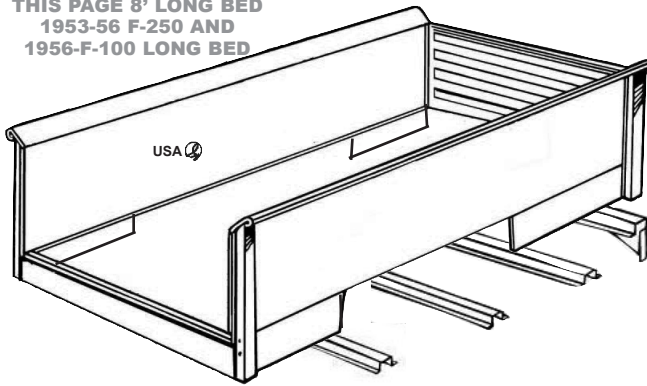

**THIS PAGE 8' LONG BED**  
 1953-56 F-250 AND  
 1956-F-100 LONG BED

**Beds and bed parts are crated and shipped freight only. Long bed sides are 14 gauge steel and VERY heavy. Freight must be quoted, we have worked very hard to get substantial discounts with the freight companies and the savings is passed on to you.**

See Also All Bed Accessories such as HOLE PLUGS, LIGHTS, ETC in standard bed section.



**Fits 1956 1/2 ton long bed & 1951-1980 3/4 Ton Ford Trucks**  
 crossmember placement is different on various years but our crossmembers are punched to accept all locations.

**BASIC KIT**, includes 2 bed sides, rear cross-member, 4 center cross members, front cross-member, zinc assembly hardware, and your choice of front bed panels.

(see pg.130 for more information on front panels)

- With Stock Ribbed Front Panel . . . . .F2-90201 . . . \$1395.00
- With Smooth (no ribs) Front Panel . . .F2-90202 . . . \$1395.00
- With Pointed Front Panel . . . . .F2-90203 . . . \$1450.00

**ADDITIONS** To Customize your bed:

- Add Center pocket, per side . . . . .F2-0204-A . . \$35.00
  - Add Teardrop installed Front, per side . . .0201-AF . . . \$50.00
  - Add Teardrop installed Rear, per side . . .0201-AR . . . \$50.00
  - Add Wheel Tub Installed, per side . . . . .F2-0219 . . \$295.00
- Includes 3" tub & installation, Note: choice of depth up to 9" larger tub may be additional charge depending on depth.
- Add polished stainless assembly hardware with acorns  
 See pg.127 for choices, All Hex, All Button
- Add your choice of tailgates and lights.

*Basic kit does not include mounting bolts, blocks or fender bolts*

*THIS PAGE IS KITS ONLY. For individual pieces, mix and match, or kits with additions or subtraction see individual pieces on the following pages.*

**Add your choice of floor kits for a complete bed kit.**

**FLOOR KIT** includes Oak boards (no hold down holes) strip and side bolts, mounting blocks and choice of strip styles & finish.(no hold down bolts, see pg.146-7 for hold down kits

**FLOOR KIT**

- With Stock Zinc strips & bolts . . . . .F2-90215-Z . . \$495.00
  - With Stainless strips & bolts . . . . .F2-90215-S . . \$550.00
  - With Polished strips & bolts . . . . .F2-90215-P . . \$650.00
  - With Polished Wow strips, & fastners .F2-90215-W . . \$695.00
- Wow strips have hidden f astners,  
 see strip pg.146 for pictures and additional information.

**HOLD DOWN BOLTS & COUNTERSUNK WASHERS**

see pg.127 for all choices

## CUSTOM LONG & LOW BED KIT (NOT STOCK)

**THIS PAGE 8' LONG BED**  
 1953-56 F-250 AND  
 1956-F-100 LONG BED

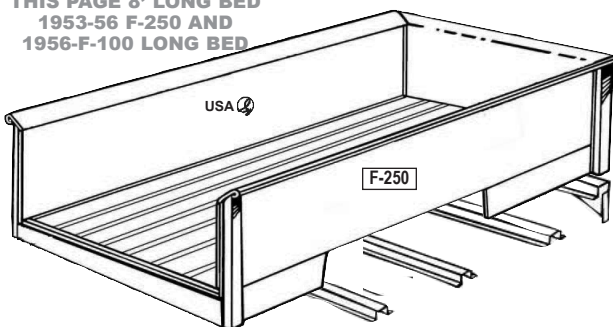

Running board extensions, see pg.141

USA

Custom and economy, this kit is just like 6 foot bed but longer. Cheaper because it uses F-100 short bed Crossmembers, Front Panel and Tailgate. Wheel tubs not needed, any stock or after-market F-100 Tailgate will fit (not included) Looks exactly like short bed just Longer, Neat. Requires moving Running board extensions back to match. Some stock long bed running boards are wide enough to accept the move, some may need modified.

Includes sides, front panel, all x-members with hidden mounting, hardware, wood and choice of strips.

**LONG AND LOW CUSTOM LONG BED KIT**

- With Plain strips . . . . .F2-90281-Z . . . \$1495.95
- With Polished strips . . . . .F2-90282-P . . . \$1550.00
- With Wow Strips . . . . .F2-90283-W . . . \$1600.00
- Long & Low Side, Driver or Pass. F2-0286-L. . . . . \$325.00 ea

Wow strips have hidden fastners, see pg.126 for picture

**CRATE CHARGES APPLY TO LONG BED SIDES**

LONG BED SECTION 8 FOOT BED