

# TOYOTA STEERING BOX CONVERSION

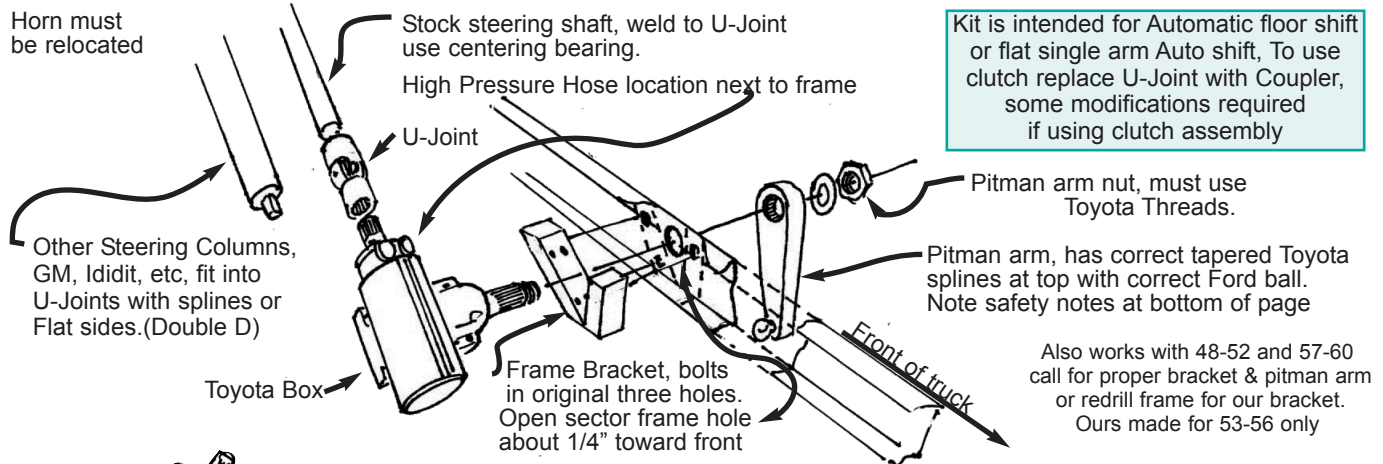

Kit is intended for Automatic floor shift or flat single arm Auto shift, To use clutch replace U-Joint with Coupler, some modifications required if using clutch assembly

**TRADE IN STOCK BOX, ANY CONDITION, only use housing, as we rebuild with new parts**

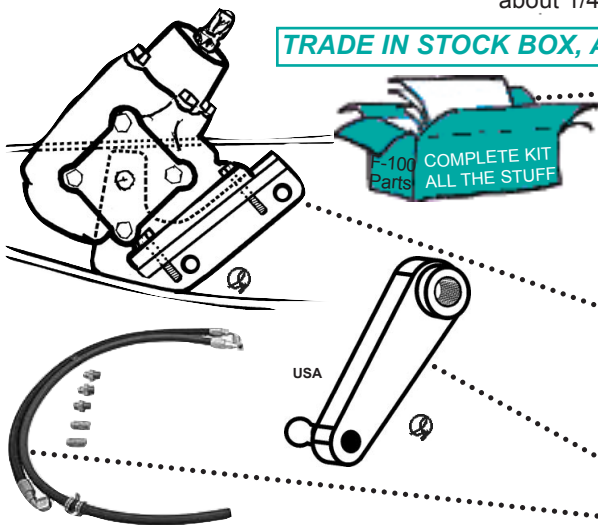

- ..... **TOY STEERING CONVERSION KITS** Mounting bracket, Pitman Arm, Sector Nut, Centering Bearing & Hardware.
  - STOCK COLUMN, With U-Joint** .....94620 ..... \$295.00 kit
  - STOCK COLUMN, With Coupler** .....94620-JC ..... \$245.00 kit
  - Add Hose Kit to any kit .....4628 ..... \$100.00 kit
  - ANY OTHER STEERING COLUMN**, (we need to know what column splines or if double D for proper U-Joint.) .....94621 ..... \$285.00 kit
- ..... **TOYOTA STEERING BOX MOUNTING BRACKET**, Bolt in, lines the box up perfectly for stock or custom column, Open hole in frame 1/4" toward front, Bolts to stock holes .....4620-CJ .....\$95.00 ea.
- BOLT KIT**, Box to bracket, bracket to frame ..84620 .....\$10.00 ea.
- OLD STYLE**, welding required, not shown .4620-OS .... \$95.00 ea.
- ..... **TOYOTA TO FORD PITMAN ARM** .....4623 ..... \$99.00 ea.
- Hardened & installed drag link ball and Toyota splines.
- ..... **HOSE KIT**, Pump to Box, High Pressure and Return line with fittings. Fittings for most pumps included .....4628 ..... \$100.00 kit
- ..... **LOWER CENTERING BEARING & RETAINER** .4625 ..... \$22.50 set
- For Stock Steering Column, holds column center as well as up & down.
- ..... **BILLET CENTERING BEARING**, high tech with roller bearings .....4626 ..... \$69.95 kit
- ..... **HORN CONVERSION KIT**, Keep your stock horn button & stock column, hand made & expensive, but works 4629 ..... \$150.00 kit
- ..... **HEAVY DUTY TIE ROD** .....2714 ..... \$49.00 ea.
- ..... **USED TOYOTA BOX** \*as available .....4621-U ..... \$325.00 ea.
- ..... **REBUILT TOYOTA BOX** lifetime guarantee. .4621-RB ... \$485.00 ea.
- Sold Exchange, you will not have a core, so core is included.
- Used box is not tested but if something is wrong we will replace it.
- Use a box from a 1980-84 and some 1985-87 Toyota 4X4 Pick-up.
- Note drawing, it must look like this one, NOT the long (about 2 ft) thin one.
- ..... **U-JOINT**, Stock Column to Toyota box ....J1116-75R .. \$79.00 ea.
- U-JOINT for any other steering column available see page 165
- ..... **COUPLER**, Stock Column, Gives more room, use if keeping clutch. See drawing above for more info. ....JC1116-75R .. \$29.95 ea.
- Coupler for any other steering column available see page 165
- ..... **TOYOTA SECTOR SHAFT NUT** .....4624 ..... \$4.65 ea
- ..... **FLOOR PLATES**, Made specifically for Toyota steering box, See page 171 for floor mounts for various columns.

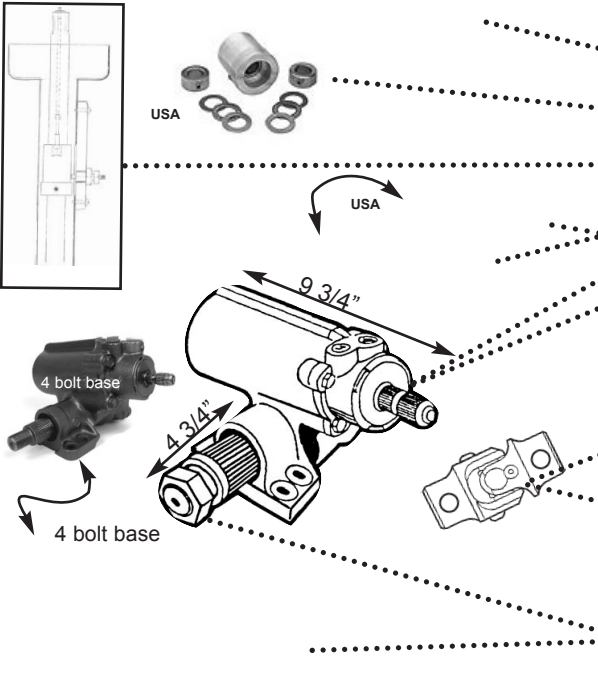

Toyota Steering conversion is a very simple and nice set up if done properly. Articles have been written and installations done using the ford pitman arm by squeezing it down on the Toyota sector shaft, literally smashing the splines together. Splines do not match. **DO NOT INSTALL YOUR STEERING IN THIS MANNER!!!!** Call us for any help or explanations, don't believe everything you read, unless you read it here, of course!

**TOYOTA STEERING**

