

HEADLINERS

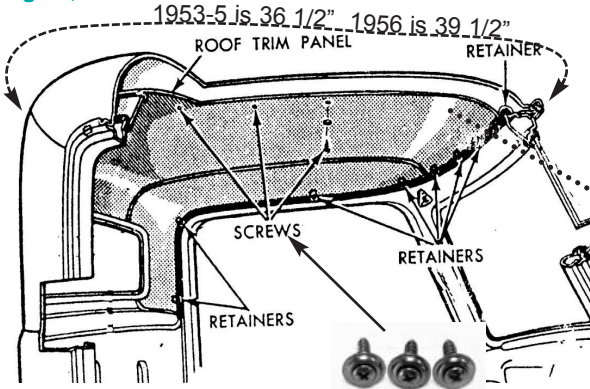

STOCK PANELBOARD HEADLINER

Stock Headliners are made of stiff Panel Board, and can be VERY DIFFICULT. You are working upside down & backwards, and making a straight piece into a curve. **Now is the time to reconsider the ABS headliners, three styles now available**

STOCK PANEL-BOARD HEADLINER, Gray Panel-board

1953-55.	2109-5355	.. \$120.00 ea.
1956 Standard Rear Window	2109-56	.. \$120.00 ea.
1956 Wraparound Rear Window	2109-BB	.. \$120.00 ea.
Headliner additional shipping	Add	.. \$50.00 ea.

TO COVER, YARDAGE NEEDED, 3 Yards

Panel truck headliner see panel truck section page 184

• **HEADLINER TRIM SCREW SET** 82110 \$1.00 set

• **HEADLINER RETAINER CLIP** 2113-EA \$.90 ea.

Complete Set of 16 2113-SET \$10.00 set

INSULATE, INSULATE, INSULATE, see below and pg.26

• **HEADLINER RUBBER RETAINER** ... 2112 \$16.50 ea.

Replace this, the newer & softer the easier it is to get the headliner in. We make 196" long to go all the way to floor for a cleaner look, originally, and others on the market are only 178" and did not go to floor but should have. Trim excess, use this with FLAT ABS headliners, "Old Style only" ABS and stock PANELBOARD headliners. If covering headliner do not overlap material to back side of panel as it will be too thick to go inside rubber, just bring material to edge and trim.

NOTE: MOLDED ABS STYLES DO NOT USE RETAINERS and ARE EASIEST TO INSTALL. SEE PAGE 25 and 26

• **FLAT ABS STOCK STYLE HEADLINERS**, Flat abs plastic, just like stock panelboard headliner, but ABS is easier to work with in curves much better than stock panelboard, plus cost is about the same, Flat ABS will roll into smaller package with less chance of damage & less shipping cost. Paint, cover or add sculpting foam shapes like the "FORD" shown below. See also matching rear wall on page 20, uses stock rubber retainer & clips.

Reconsider New Style ABS molded headliner, see next page.

Oversize shipping add \$25.00

1953-55 FLAT ABS, BLACK 2111-5355 .. \$185.00 ea.

1956 FLAT ABS, BLACK 2111-56 ... \$185.00 ea.

TO COVER, YARDAGE NEEDED, 3 Yards

• **HEADLINER INSULATION KIT**, Includes pre-cut sound dampeners, Roof insulation and side of window Insulation, high temp adhesive, aluminum tape & Instructions

1953-55 Standard window 92176-5355 ... \$89.00 kit

1956 Standard window 92176-56 \$89.00 kit

1956 Big Wrap around window 92177-56BB ... \$89.00 kit

• **OVERDONE DAMPNER KIT** 92166-(yr) \$66.00 ea
see page 24, 25 for more info.

• **DIE CUT FORD LOGO**, just peel and stick to any surface, glue and smooth fabric over shape and Ta-Da, Custom!! One is the outside one is the inside 2119-FD \$14.95 ea.

SALE, 2 for, save \$10.00 2119-FD2 ... \$19.95 pr.

V8 not shown, BIG SALE 2119-V8 \$10.00 ea.

• **HI-TEMP SPRAY ADHESIVE** 2103 \$13.95 ea
Use on firewall, roof, floor, any place temps will get high

• **UPHOLSTERY ADHESIVE** 2102 \$13.95 ea

