

# CAB TO RUNNING BOARD SKIRT

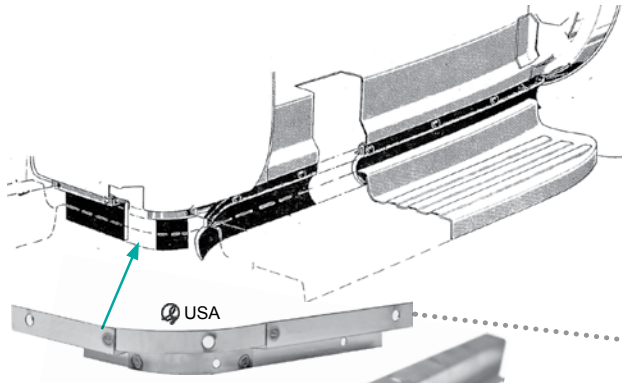

## 1956 CAB SKIRTING

1956 side and corner hangers secure to lower cab lip then go back under cab an inch before turning downward to hold skirt. Skirt ends up in same position as 1953-55. This is a good choice for cabs with imperfect edges. It straightens up the lower cab lip line and covers any damaged areas. Can be spot welded or secured with screws, clips or bolts, was originally attached with original style clips (difficult to use and expensive). 56 Hanger goes on outside of cab lip, 1953-55 goes inside.

### 1956 CAB SKIRT HANGERS

Can also be used on 53-55. These show, polished stainless is a nice touch. Large holes go up

#### Corner hanger

- Stock steel driver ..... 7732-L ..... \$16.50 ea
- Stock steel passenger ..... 7732-R ..... \$16.50 ea
- Polished stainless, order R or L..... 7734-PS ..... \$28.50 ea

#### Side hanger

- Stock steel ..... 7731 ..... \$16.50 ea
- Polished stainless ..... 7731-PS ..... \$28.50 ea

#### Hanger mounting bolts

- Stainless ..... 80306-SS ..... \$12.00 set
  - Polished stainless button head ..... 80306-PB ..... \$22.00 set
  - Original "X" clips ..... 80309 ..... \$1.50 ea
- Use if going exact of original, hard to work with & expensive

### 1956 CAB SKIRT RUBBER

0304-56 ..... \$14.50 pr  
If you want to fight with original staples, good luck..... FREE  
If not, order attaching push clips or screws below

Small piece, for corner or? ..... 0303-CNR ..... \$8.90 pr  
Attaching hardware, not original see above

- Plastic push clips (20)..... 80305-56 ..... \$3.50 set
- Polished stainless screws..... 80307-PS ..... \$14.50 set

### 1956 CAB SKIRT AND HANGER KIT

- 2 corners, 2 side channels, all rubber skirts & push clips
- Stock steel ..... 97732-56 ..... \$89.95 kit
- Polished stainless ..... 97732-PS ..... \$159.95 kit
- Sides only, no corners, steel..... 97731 ..... \$47.50 kit

## 1953-55 CAB SKIRTING

1953-55 hanger channels should be attached to a small lip on bottom of cab. If your's no longer has usable lip, see above, or a neat fix is to use the Up-Side Down style that attaches to running board and points UP toward cab.

UPSIDE DOWN CAB SKIRTING ..... 0305 ..... \$48.50 pr

### 1953-55 CAB SKIRT HANGER CHANNEL

This piece does not show below door, it goes on inside of lip, "C" points toward inside of cab

- Plain steel ..... 7730 ..... \$12.00 ea
- Polished stainless ..... 7730-PS ..... \$15.00 ea
- I know it doesn't show, but, no painting, no rust, worth extra \$
- Hardware kit ..... 80303 ..... \$6.50 set

Polished stainless, screws go all the way through the rubber into clips. We include 4 extras to go around corners

1953-55 CAB SKIRT RUBBER ..... 0304-5355 ..... \$19.50 pr  
Hangs from "C" channel, is attached around corners with screws.

### 1953-55 CAB SKIRT AND HANGER KIT

- 2 side hanger channels, 2 skirts and hardware kit.
- Plain steel (polished screws) ..... 97730-5355 ..... \$47.95 kit
- Polished stainless ..... 97730-PS ..... \$53.95 kit

### CUSTOM STAINLESS SKIRTS

With hardware ..... 7304-FLX ..... \$65.00 kit  
Easy to install, polished stainless flexible steel, replaces rubber.

Note: 1953-55 Trucks may need corner hangers at top of page

