

# FRONT HOOD FLIP KITS

(CANTILEVERED: means hood is now secured at the other end)

Flipping the hood can solve many a "fit" problem, by sliding hood forward and up gives more access to engine area than before. Also with kit installed hood is adjustable in all four corners for a more uniform and smooth fit.

**For both kits** listed here, do not use safety latch (the one on pass side) or cowl lacing with any flip style hood kit as they pull forward first, then up, and will catch on cowl lace and latch. Use center latch, adjust striker plate accordingly. Hood alignment rods not needed but fender alignment rods are. Note how hood pulls forward first, this requires a different style hood lace so hood lip will not catch. Use hood bumpers or rubber lacing on hood instead, listed below

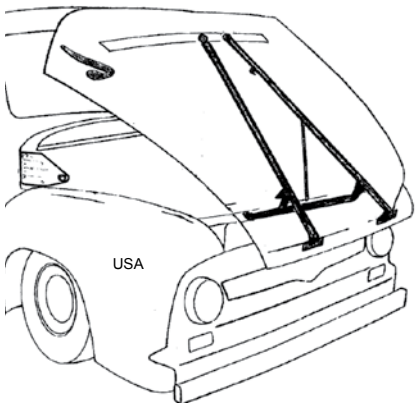
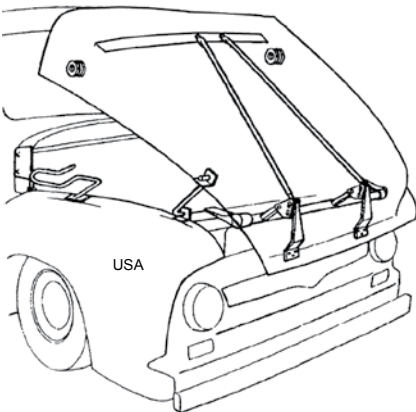

## MMB HOOD TILT KIT

Complete kit, no BMW parts. Very simple to install using stock mounting locations and holes. Safety hood prop mounts down in front for security and complete engine access, plus a neat rubber hood bumper holder. Includes cover plates for original hinge mounting area. This kit is a little easier to install and a little heavier in construction than the other one below.

### MMB hood tilt kits

Plain.....	2030 .....	\$350.00 kit
With polished stainless ramps & prop .....	2030-PBP .....	\$449.00 kit

### Individual pieces

*For updates or, if you bought kit elsewhere tisk-tisk*

Roller ramp polished stainless, drive.....	2037-PSL .....	\$65.00 ea
Roller ramp polished stainless, pass .....	2037-PSR.....	\$65.00 ea
Roller shoulder bolt, polished/chrome .....	2039-PL .....	\$9.00 ea
Prop rod assembly, polished stainless .....	2036-PS .....	\$65.00 kit
Hinge hole covers.....	2038-PS .....	\$59.00 pr
Hinge hole chrome plugs (8) .....	82025 .....	\$5.00 set
Prop rod rubber bumper holder .....	2035-BMP .....	\$6.00 ea

## Y2K BILLET FLIP KIT

Roller is on a billet aluminum piece that mounts in existing hinge location. Track is up inside hood, and in billet aluminum. Hood braces double as adjusting rods with adjustable ends. Front hood assembly also adjusts for a perfect and easy fit, comes with threaded plates for easy installation. Prop rod rides on hood brace and props to core support out of the way

<b>Y2K billet flip, complete</b> .....	2040 .....	\$339.00 kit
<b>Billet update kit</b> .....	2041-UP .....	\$139.95 kit

Converts older style BMW kit with roller ramps on fender to new style with billet aluminum roller mounts on cowl and billet aluminum ramps in hood

## OTHER PARTS

<b>Hood to cowl bumpers</b> .....	82006(size).....	\$6.90 set
<i>Order by height, 3/8", 7/16" is about right, 1/2" or 5/8". There are usually 9 holes but have seen more, so we send you 11 pcs.</i>		
<b>Hood-cowl lace, protective bumper</b>		
Domed style, self stick.....	2006 .....	\$12.00 ea
Cowl lace rubber, glue inside hood.....	2007-R.....	\$10.00 ea
Holes still there? Polished screws .....	82008 .....	\$5.00 set

