

# BED PARTS & CROSSMEMBERS

No hold down bolts showing  
Hidden Mounting

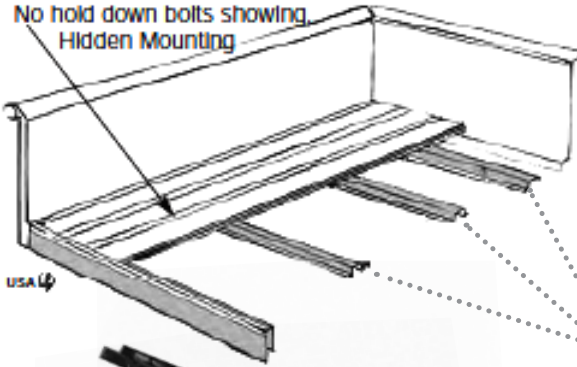

Beds mount to the frame in 8 locations. Two at the front through the bed strip into a sleeve on the front crossmember then into a bracket on the frame (0234). 4 bolts go through bed wood with large concave washers countersunk into the wood, through x-member and into frame. The last 2 mount rear x-member bracket into frame. Bed can be mounted as a complete assembly or assembled on the truck. Hidden x-members have threads inside so can be attached to the frame from underneath so that no mounting bolts show inside bed, this allows the bed to be installed or removed as one unit.

## STOCK STYLE CROSSMEMBERS

- Front ..... 0230 ..... \$45.00 ea
  - Center (use 2, they face each other) ..... 0232 ..... \$45.00 ea
- One side is shorter, it faces the axle on the slope of frame*

## HIDDEN MOUNT STYLE CROSSMEMBERS

- Front ..... 0230-HD ..... \$55.00 ea
  - Center ..... 0232-HD ..... \$55.00 ea
  - Hidden mount bolt kit ..... 80230 ..... \$8.00 kit
  - Hidden bed mounting kit ..... 90200-HD ..... \$165.00 kit
- Includes front and 2 center crossmembers, hardware & insulators.*

## REAR Crossmember

*Complete with mounting brackets. We offer many different styles of the rear sill, these two are stock style.*

- Stock style, USA made ..... 0233 ..... \$75.00 ea
  - Stock style, imported (China) ..... 0233-B ..... CALL
  - Crossmember to frame bolts ..... 80233 ..... \$3.50 set
  - Crossmember mount, die stamped ..... 0235 ..... \$15.00 ea
- Just like original, not just a L-bracket like all others on market.*

## REAR X-MEMBER REPAIR OR COVER

*Quick and easy. Slips over rear sill.*

- Plain steel (can spot weld for repair) ..... 0221-RZ ..... \$32.50 ea
- Polished stainless ..... 0221 ..... \$42.50 ea
- Louvered, polished stainless ..... 0221-LV ..... \$57.50 ea

## REAR SILL & WOOD CAP COMBO

*Covers rear crossmember and bed wood ends. This has always been a spot I felt needed some "clean up". So, this piece replaces bed end cap, covers wood, then comes down and covers rear sill. Stock end cap bolt locations hold the top and I turned it under so a couple little screws would secure bottom out of sight. Neat, clean and covers any dings in rear sill.*

- Plain steel ..... 0221-CZ ..... \$38.50 ea
- Polished stainless ..... 0221-CP ..... \$55.00 ea
- Bolt kit, same as rear end cap ..... 80204-PS ..... \$6.90 set

## LONG BED CROSSMEMBERS See long bed on page 136

## HOLD DOWN BOLTS see page 122

## DROPPED REAR SILL

- Complete kit ..... 90237 ..... \$219.95 ea
- Use in place of roll pan. Dropped sill with dropped extensions & curved end caps for stake pockets brings rear down to meet fender, makes truck look lower and brings bed more in line with bumper. Requires welding*
- Dropped rear bed extensions ..... 0238 ..... \$50.00 pr
  - Dropped rear stake pockets
  - Straight flat open bottoms ..... 0239 ..... \$99.95 pr
  - Curved closed bottoms front ..... 0239-XF ..... \$150.00 pr
  - Curved closed bottoms rear ..... 0239-XR ..... \$150.00 pr
  - Dropped rear sill (crossmember) ..... 0237 ..... \$135.00 ea
  - Dropped rear sill with lights ..... 0237-(style) ..... \$250.00 ea
- Custom cut, flames, Ford, ovals. Made to order*

