

SOLID SIDE WINDOW, 1953-55

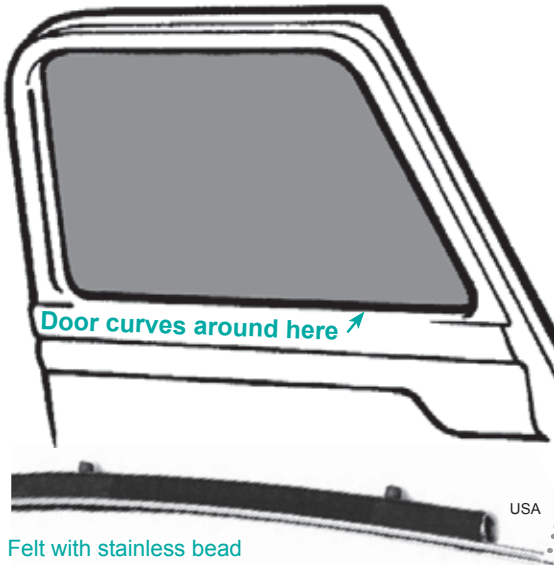

Some 1953-55 glass passes too far up into the outer corner, best solution for this is to split back of felt channel for about 5 inches in the corner, letting glass pass through slit when rolled all the way up.

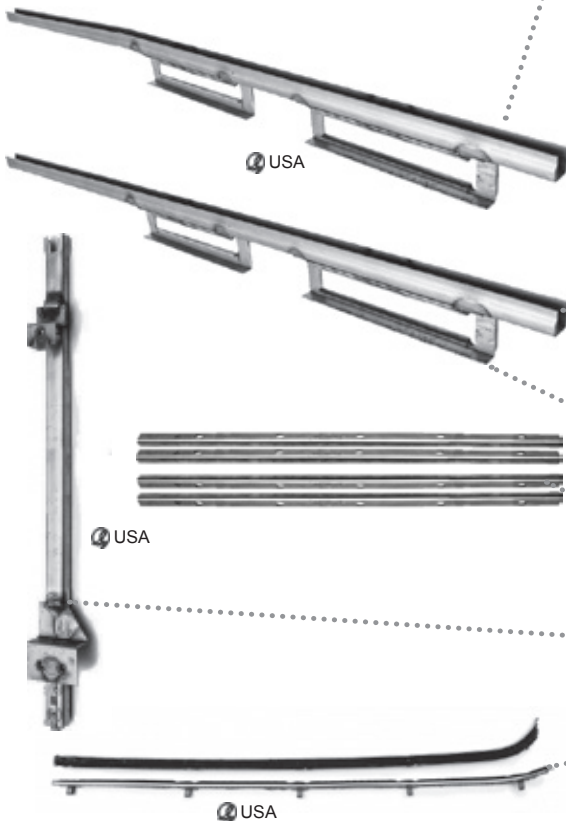

1953-55 CURVED GLASS KIT

1953-55 doors have a slight curve, and upper hinge and adjoining sheet metal is in the way when eliminating vents. To install solid side windows you need kit with curved glass, OR you need to straighten glass opening. This can be done with our straighteners, but it's a lot of body work as you cut out inner angles along door glass opening and replace with straight pieces. This CURVED GLASS kit can be installed in a finished truck without all that body work as the only cutting is hidden behind door panel. Comes with instructions, upper & back felt runs, lower felts, and everything you need to install. Oversized shipping

KIT WITH STAINLESS BEAD FELTS

Clear glass.....	91724-C.....	\$365.00 kit
Tinted glass	91724-T	\$365.00 kit
Smoke glass	91724-S.....	\$365.00 kit

KIT WITH NO BEAD, BLACK

Clear glass.....	91725-BC	\$365.00 kit
Tinted glass	91725-BT.....	\$365.00 kit
Smoke glass	91725-BS	\$365.00 kit

EXTENDED LIFTS FOR CURVED GLASS

Pair, ordered with kit, additional.....	1730-CX	\$39.00 pr
---	---------------	------------

Bottom of curved glass needs CURVED extended lift IF using stock window regulators, NOT needed with power window kits

For best results use the power window kit and the power window install kit on page 96

1953-55 FLAT GLASS KIT

Flat glass, door curve must be straightened, metal angle pieces to straighten door are included. Oversized shipping

KIT WITH STAINLESS BEAD FELTS

Clear glass.....	91721-C.....	\$350.00 kit
Tinted glass	91721-T	\$350.00 kit
Smoke glass	91721-S.....	\$350.00 kit

KIT WITH NO BEAD, BLACK

Clear glass.....	91720-NC	\$350.00 kit
Tinted glass	91720-NT	\$350.00 kit
Smoke glass	91720-NS	\$350.00 kit

EXTENDED LIFTS FOR FLAT GLASS

Pair, ordered with kit, additional.....	1731-53AD	\$39.00 pr
---	-----------------	------------

INDIVIDUAL SOLID SIDE PIECES

1953-55 EXTENDED LOWER LIFT

Use with stock regulators, or if NOT using our TEMPERED glass, Laminated glass may break without support.

Order left or right	1731-5355X(R-L).....	\$39.00 ea
---------------------------	----------------------	------------

DOOR WINDOW SILL STRAIGHTENER STRIPS

Set of inner and outer for each door

Set of 4	3113-4	\$39.95 set
----------------	--------------	-------------

LOCK SIDE UPPER & BACK CHANNEL BRACKET

Piece upper & back channels slide into, attached to latch (back) side of door above & below star.

Driver side	3114-L.....	\$40.00 ea
Passenger side.....	3114-R.....	\$40.00 ea

LOWER FELT WIPES

Formed, with clips, does one door

Stainless bead	1727-5355	\$50.00 pr
Black bead.....	1727-5355B.....	\$50.00 pr
Do-yourself, black bead, glue in	1727-BK	\$17.50 pr
Do-yourself, stainless bead, glue in ..	1727-ST.....	\$17.50 pr

DRY GRAPHITE small tube	3128-23	\$2.95 ea
-------------------------------	---------------	-----------

