

9 FOOT LONG BED

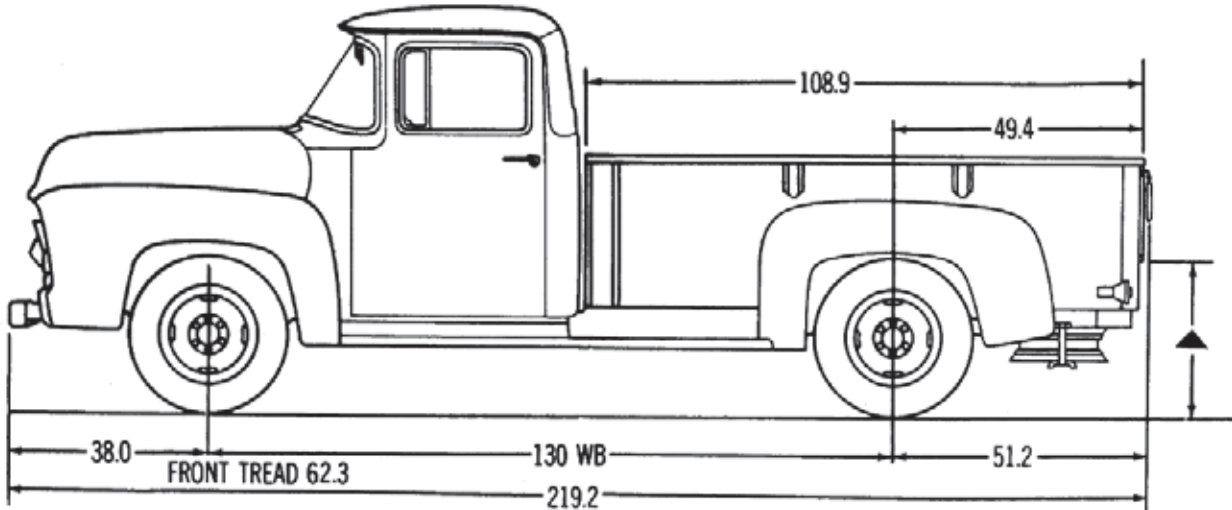

ALL DIMENSIONS WITH 8 x 17.5-6 P.R. TIRES (LOADED)

9 Foot bed will fit on 1948 through 1983 with some changes in crossmembers and fender holes. The bed side we make are 14 gauge heavy weight steel. This bed is heavy and requires crating, special handling and truck freight. We will work up a quote with the best possible truck line and pass our discounts on to you. The front panel, tailgate, crossmembers, hinges, latches, bolt kits, covers, running board braces, etc are the same as the 8 foot beds, see previous long bed pages for all the choices. 9 Foot beds do not come in kits. Bed sides come with no fender holes, sides fit many years with various fender hole patterns (6.5' bed sides have holes) and come with smooth angles, no holes in side angle for stake pockets

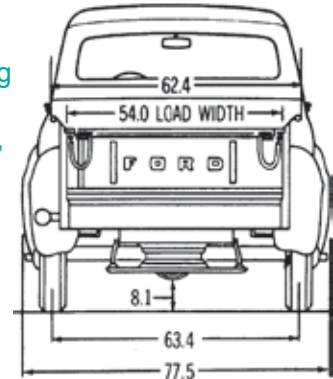

- CROSS-MEMBERS same as F-250 8 ft. bed, see previous 8 foot bed pages
- BOLT KITS same as F-250 8 ft. bed, see previous 8 foot bed pages
- FRONT BED PANELS same as F-250 8 ft. bed, see previous 8 foot bed pages
- TAIL GATES same as F-250 8 ft. bed, see previous 8 foot bed pages
- COVER, TONNEAU & SUPPORTS, see page 129

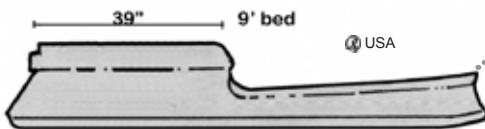

ONE TON LONG BED STEEL RUNNING BOARDS

Heavy gauge steel, hand made, include side panel.

- Smooth steel, driver.....F3-0307-L.....\$335.00 ea
- Smooth steel, passenger.....F3-0307-R.....\$335.00 ea



RUNNING BOARD BRACES ARE SAME See page 113

F-350 RUNNING BOARD TO BED SIDE PANEL, STEEL

- DriverF3-0332-L.....\$48.50 ea
- PassengerF3-0332-R.....\$48.50 ea

THIS PAGE CONTAINS LONG BED PARTS ONLY

