

# POWER STEERING CONVERSIONS

Bleeding power steering, yes, it does need done. Power steering systems are "self-bleeding" but we are installing new components. With truck off, fill reservoir and let sit for a bit, raise the front end and turn wheels back and forth slowly (engine is still OFF) allow the box to draw fluid, keep adding fluid to reservoir, keeping it full, when level stops dropping, start truck and continue to turn wheels until fluid stays full. Put cardboard, upside down rug, etc under front tires, will let tires slide on concrete floor, saves tires, floor and your back. New steering having trouble? If the problem is on one side or one direction, check box or rack or pitman arm areas. If problem is on both sides or directions, it is probably the pump, the fluid or hoses, do the bleeding procedure above.

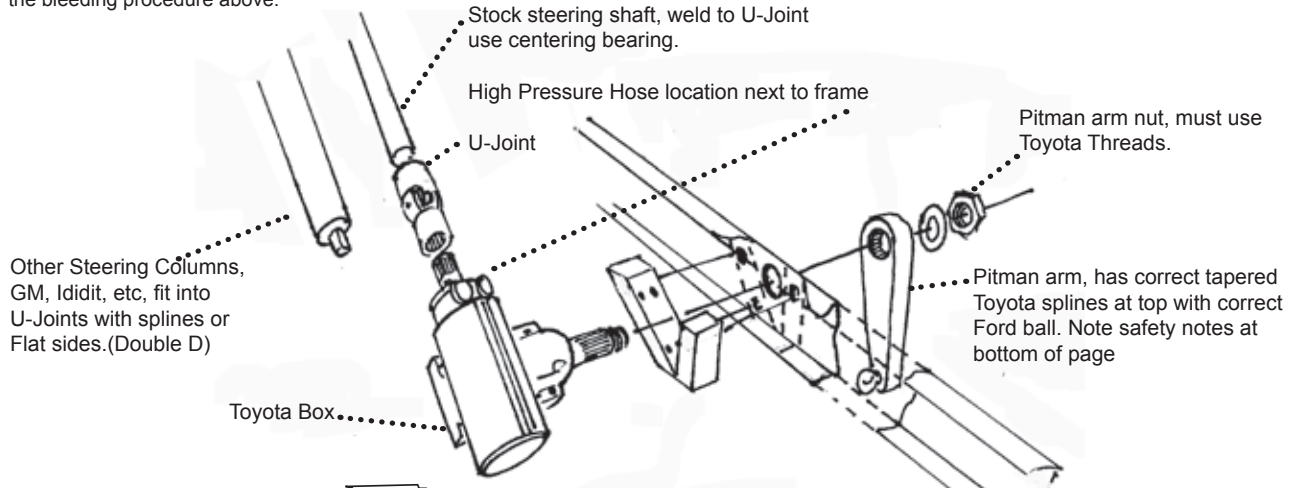

## TOYOTA CONVERSION

### TOYOTA STEERING CONVERSION KITS

*Bracket, pitman arm, sector nut, centering bearing & hardware.*

- Stock column, with u-joint ..... 94620 ..... \$265.00 kit
- Stock column, with coupler ..... 94620-JC ..... \$220.00 kit
- Another steering column, call first ..... 94621 ..... \$235.00 kit

### TOYOTA TO FORD PITMAN ARM

- ..... 4623 ..... \$79.00 ea

*Hardened & installed drag link ball and Toyota splines.*

### BOX MOUNTING BRACKET

- ..... 4620-CJ ..... \$95.00 ea
- Bolt in, lines the box up perfectly for stock or custom column, Open hole in frame 1/4" toward front*

### BOLT KIT

- Box to bracket, bracket to frame .... 84620 ..... \$10.00 kit

### OLD STYLE BRACKET

- Welding required... 4620-OS ..... \$95.00 ea

### HOSE KIT

- ..... 4628 ..... \$100.00 kit

### USED TOYOTA BOX

- as available..... 4621-U ..... \$325.00 ea

### REBUILT TOYOTA BOX

- ..... 4621-RB ..... \$585.00 ea

*Used box is not tested but if something is wrong we will replace it. Use a box from a 1980-84 and some 1985-87 Toyota 4X4 Pick-up.*

### TOYOTA SECTOR SHAFT NUT

- ..... 4624 ..... \$8.00 ea

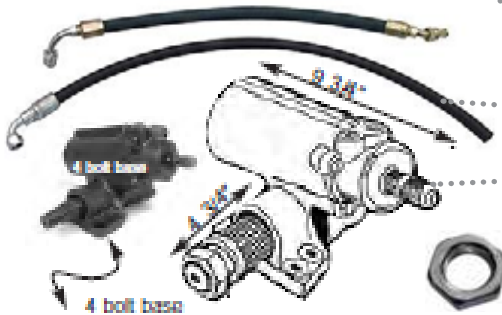

## 400 SERIES POWER STEERING

*The compact design is closely modeled after the original manual steering box. With its 13.6:1 ratio (2.75 turns lock to lock) it has the performance handling of many rack and pinion conversions without the need for extensive modifications. Cheaper than our old Toyota conversion with a used box, and this is all NEW!*

- Complete kit ..... 4614-5356 ..... \$535.00 ea
- Box only..... 4613-5356 ..... \$375.00 ea



Toyota Steering conversion is a very simple and nice set up if done properly. Articles have been written and installations done using the ford pitman arm by squeezing it down on the Toyota sector shaft, literally smashing the splines together. Splines do not match. **DO NOT INSTALL YOUR STEERING IN THIS MANNER!!!!** Call us for any help or explanations, don't believe everything you read, unless you read it here, of course!