

POWER STEERING CONVERSIONS

Bleeding power steering, yes, it does need done. Power steering systems are "self-bleeding" but we are installing new components. With truck off, fill reservoir and let sit for a bit, raise the front end and turn wheels back and forth slowly (engine is still OFF) allow the box to draw fluid, keep adding fluid to reservoir, keeping it full, when level stops dropping, start truck and continue to turn wheels until fluid stays full. Put cardboard, upside down rug, etc under front tires, will let tires slide on concrete floor, saves tires, floor and your back. New steering having trouble? If the problem is on one side or one direction, check box or rack or pitman arm areas. If problem is on both sides or directions, it is probably the pump, the fluid or hoses, do the bleeding procedure above.

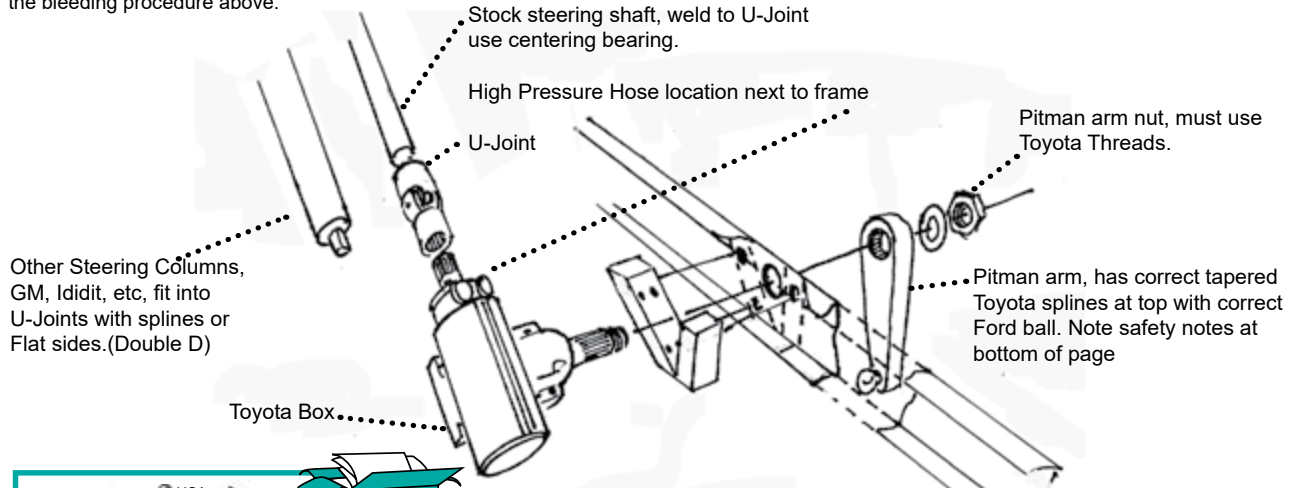

TOYOTA CONVERSION

TOYOTA STEERING CONVERSION KITS

- Bracket, pitman arm, sector nut, centering bearing & hardware.*
- Stock column, with u-joint 94620 \$265.00 kit
- Stock column, with coupler 94620-JC \$220.00 kit
- Another steering column, call first 94621 \$255.00 kit
- TOYOTA TO FORD PITMAN ARM 4623 \$79.00 ea
Hardened & installed drag link ball and Toyota splines.
- BOX MOUNTING BRACKET 4620-CJ \$95.00 ea
Bolt in, lines the box up perfectly for stock or custom column, Open hole in frame 1/4" toward front
- BOLT KIT Box to bracket, bracket to frame..... 84620 \$10.00 kit
- HOSE KIT 4628 \$100.00 kit
- USED TOYOTA BOX as available..... 4621-U \$325.00 ea
- REBUILT TOYOTA BOX 4621-RB..... \$585.00 ea
Used box is not tested but if something is wrong we will replace it. Use a box from a 1980-84 and some 1985-87 Toyota 4X4 Pick-up.
- TOYOTA SECTOR SHAFT NUT 4624 \$8.00 ea

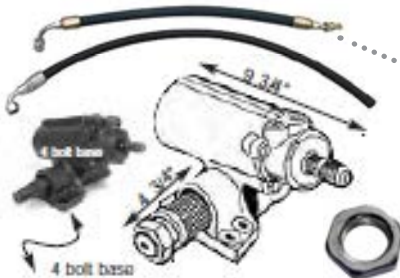

400 SERIES POWER STEERING

Best buy, easy install, all new parts

Compact design closely modeled after original manual steering box. A 13.6:1 ratio (2.75 turns lock to lock) gives performance & handling of rack and pinion conversion without need for extensive modifications. Cheaper than our old Toyota conversion with used box, and is all NEW



- COMPLETE KIT 4614-5356 \$535.00 EA
- BOX ONLY 4613-5356 \$379.00 ea
- HOSE KIT 4628 \$100.00 kit

see previous page for rag joint or U-joint.



- COLUMN CENTERING DELRON BUSHING & SLEEVE
Use at bottom of column..... 4625.....\$22.50 kit
- HORN ADAPTING KIT, to use original horn button & column with Toyota or 400 Series conversions 4629.....\$150.00 kit