



Ready-to-Install Auto Upholstery & Carpet Kits  
Original, Restoration & Custom

1575 W. Broadway Ave., Anaheim, CA 92802

Tel: 800-235-8974 or 714-774-9506 Fax: 714-774-0788 Web: seatzmlg.com

## PICKUP BED TONNEAU COVER – VELCRO VERSION

1. Test fit the Tonneau to get an idea of the fastening points of the Sewn-on Loop Velcro. This is best done with a second person as a helper.
2. Thoroughly clean all surfaces of the pickup bed where you will be applying the Peel & Stick Adhesive Hook Velcro. The Metal surface must be free of wax, residues and oxidation. Rubbing alcohol works well.
3. Apply Velcro Hook **SOLIDLY** to the metal as shown, especially at the ends. The best technique is to peel back a small portion of the protective tape, position and apply the exposed adhesive Velcro at one end, pull the Velcro tight from the other side to form a straight line and then gently peel back the protective tape and press the adhesive backed Hook down on the metal. Go back over the Velcro Hook with pressure to assure a good bond of all surfaces.
4. Tonneau can be test fitted but after test, remove the Tonneau and re-press the Velcro Hook onto the truck. **LEAVE THE TONNEAU OFF FOR 72 HOURS!** The adhesive is activated by pressure and has less than a third of its final strength immediately after installation!

## PICKUP BED TONNEAU COVER – SNAP-ON VERSION

1. Check all surfaces of the Aluminum Rails for burrs – smooth as needed.
2. Position the Rails on top of the front wall of the pickup bed with the open channel forward toward the cab and the flat mounting surface toward the rear (as shown). The Rails come in two pieces for easier shipping. Position the Rails with the ends touching each other at the center (no space).
3. Use the Rails as templates and mark and drill holes in the bed wall top. Size the hole properly for the supplied screws and truck bed wall thickness.
4. Once the Rails are installed, feed the edge of the Tonneau Cover that has the sewn-in round cord into the Rail Channel and center the Tonneau Cover across the front wall. The corded edge may slip out when pulled directly away from the channel but will not pull out when pulled back toward the rear. If you find it difficult to feed the corded edge into the track, try using some spray silicone.
5. Next, install the Snap Screw Studs. Start with the front outer corners - the forward most snaps on the sides closest to the front wall. Pull the Tonneau Cover tight across the bed before marking a spot to drill – **THIS IS BEST DONE WITH TWO PEOPLE.** Mark, drill and install a Snap Screw Stud on one side, attach the Tonneau Cover and then install the Snap Screw Stud on the opposite side. Next, install the Snap Screw Studs at the back outer rear corners of the side bed rails. Make sure you pull the Tonneau Cover Tight for the best look. Next install the Snap Screw Stud for the Rear Gate center. Next, install the remaining Studs on the Rear Gate working outward from the center. Last, install the Studs on the side bed rails starting in the middle. Alternate sides and work outboard from the middle.

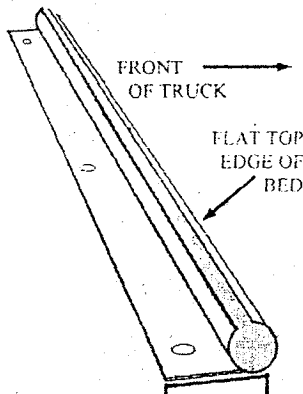

Snap Version Front Channel Rail

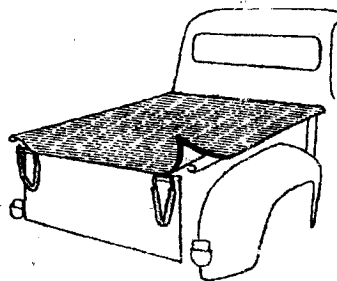

Tonneau Cover Installed

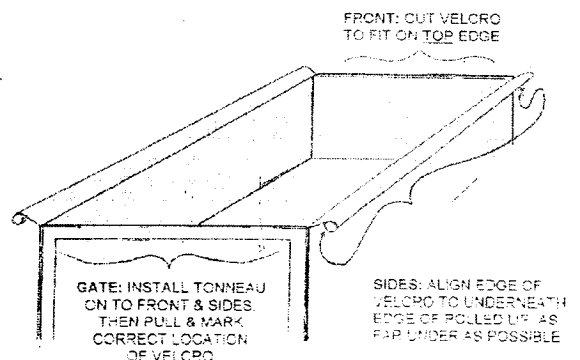

Velcro Version