

This unit will work only with original dash fuel gauges, not after market gauges.

This unit will work with either 6 or 12 volt systems.

This unit works in 1936-55 Ford/Mercury cars, 1936-55 Ford pickups, 1955 T Birds

Note that the float arm supplied with this sending unit is of an unspecified length and must be altered to fit your gas tank depth.

FLOAT ARM PREPARATION

- Remove the float arm from the sending unit. Remove the float from the arm.
 - Determine the **FLOAT ARM CUT LENGTH** required for the gas tank depth. (refer to the **FLOAT ARM LENGTH GUIDE**). Cut the float arm to the specified length.
 - Determine the **FLOAT ARM BEND LENGTH**. (refer to the **FLOAT ARM LENGTH GUIDE**). Bend the end opposite of the Shepherd's hook to a sharp 90 degree angle. The measurement from the end to the 90 should be 7/16" to 1/2". Note that when the bending procedure has been completed, the bend will be parallel to the axis of the float and the open end of the Shepherd's hook will be pointing up when the arm has been inserted into the sending unit. (see **ILLUSTRATION A**)
 - Insert the bent end of the float arm into the hole on the side of the sending unit then snap the arm into the rheostat follower. Reinstall the float onto the arm.
- If the unit is side mounted, the float arm will require some additional adjustment.

FLOAT ARM LENGTH GUIDE

TANK DEPTH (inches)	CUT LENGTH (inches)	BEND LENGTH (inches)
6	4 7/16	3 11/16
6 1/2	4 15/16	4 3/16
7	5 1/2	4 3/4
7 1/2	6 1/16	5 1/4
8	6 9/16	5 13/16
8 1/2	7 1/8	6 3/8
9	7 5/8	6 15/16
9 1/2	8 3/16	7 7/16
10	8 3/4	8
10 1/2	9 1/4	8 1/2
11	9 5/8	9 1/16
11 1/2	10 3/8	9 5/8
12	10 7/8	10 1/8
12 1/2	11 7/16	10 11/16
13	11 15/16	11 1/4

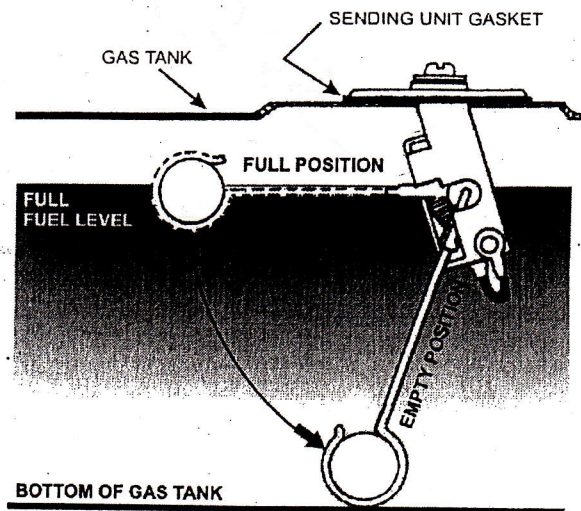
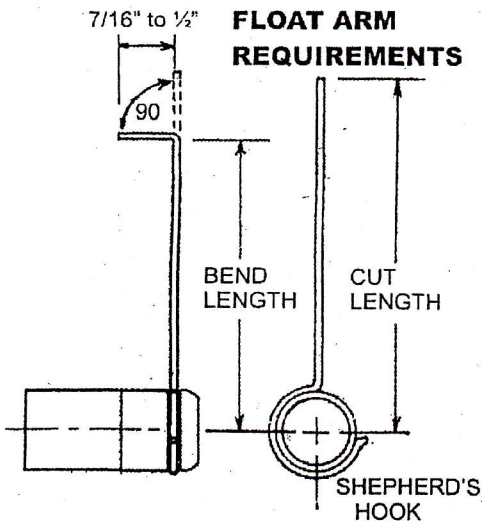
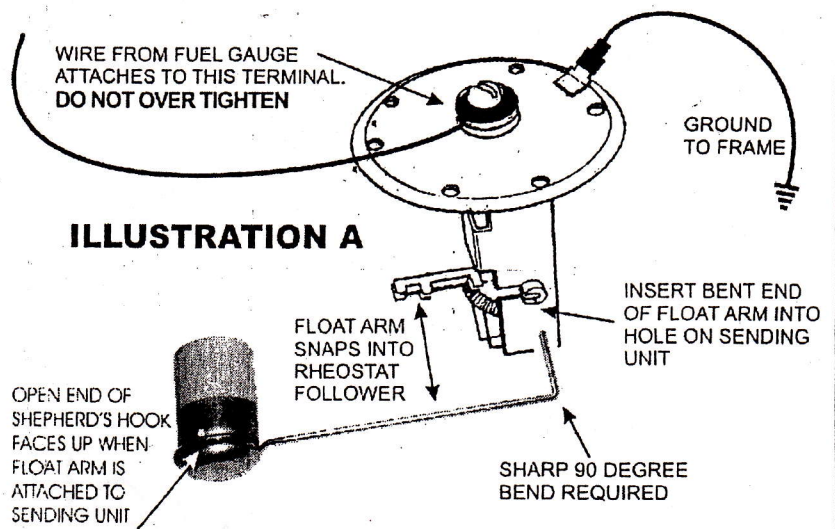

THE FLOAT SHOULD REST ON THE BOTTOM WHEN THE GAS TANK IS EMPTY.