

REAR AXLE MOUNT KIT SPRINGS ABOVE, Standard

PART NUMBER
INST-2881
2881-WSS
2888
PAGE NUMBER
1 of 2

#@\$!*@#\$\$% INSTRUCTIONS

MID FIFTY F-100 PARTS 1-800-252-1956

- KIT INCLUDES:
- 2 Axle Pads
 - 2 U-Bolt Plates
 - 4 U-Bolts
 - 1 Pack of U-Bolt Hardware
 - 2 Weld-on Shock Mounts
 - 2 Shock Mount Studs (in WSS kit only)

NOTE: Kit is designed for 48-56 Fords

or any others with 2" leaf springs and 3" axle housing like 55-59 Chevy Trucks

This kit is designed to mount the springs above the axle like it was originally

Prep your axle housing by removing any existing mounts.

Mount the springs to the chassis. Of course check all bushings etc.

Use existing mounts or check our catalog for lowering tips, etc.

Front spring hangers can be raised and or flipped at this time, various 'Y' hangers, spring packs and main leaves are available, lowered, etc.

1. Start by setting the chassis up on jack stands, level the chassis all around. Use a jack to lift the axle up to the springs. Place the axle pads on top of the axle and lift axle up against the springs with light pressure.
2. Carefully measure from the springs to the housing ends to center the rear axle housing. Next, set the pinion angle to 0 degrees, this will give you a perfect setting at ride height. Tack weld the axle pads to the housing.

3. Position the shock mounts directly under the frame rails 32" on center. Set the mount facing straight up and down and tack weld them to the housing. (these measurements are correct for the 55-59 Chevy Truck as well) Install shock studs, studs should stick out at a 90 degree angle. (see point (A))

4. Remove the axle housing and weld up the mounts. Bolt the housing back into place.

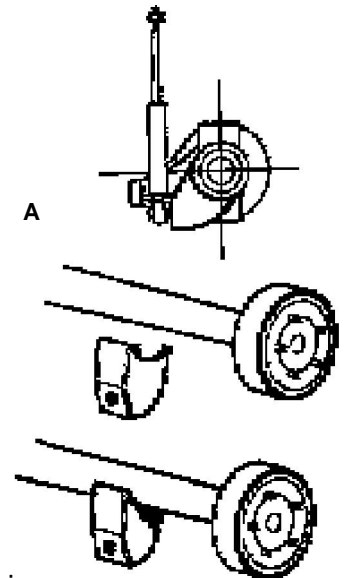

SPRING PAD

'U' BOLT

SHOCK STUD
LOCATION

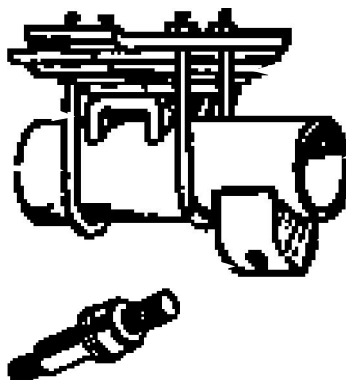

SPRING PACK

AXLE HOUSING

SHOCK MOUNT

SHOCK STUD #2403

REAR AXLE CONVERSION REAR END CENTERLINE

2881
2881-WSS
2882
2882-WSS
2888

#@\$!*@#\$\$% INSTRUCTIONS

MID FIFTY F-100 PARTS 1-800-252-1956

HOW TO FIND THE REAR END CENTERLINE

When swapping out the rear end in your classic truck to a newer unit, the axle centerline must be found in order to insure the correct placement of the shock mounts and leaf spring seats.

Before any measurements are taken, make sure that the rear end is centered between the frame rails. With the rear end centered, measure the width of the rear end hub and divide that number by 2. The result will be the distance from one hub to the axle centerline. Remember, if the measurement is correct, then the distance from either hub to the centerline will be the same no matter what rear end is being used.

Now that the centerline has been determined it will be easy to place the spring axle seats and shock mounts. The location of each spring seat (A) should be the same distance from the centerline. Likewise, the location of each shock bracket (B) should be the same distance from the centerline.

