

Steering, Brake & Suspension Specialists

#CP169 - Rear Sway Bar Kit Instructions for 1948 -1960 Ford F-100, 1947-1959 GM Truck

Parts List:

1 ea. Sway Bar	2 ea. 90° End Link Brackets
2 ea. Sway Bar Bushings	2 ea. Flat End Link Brackets
2 ea. Sway Bar End Links	6 ea. 3/8-16x1" Bolts
2 ea. Saddle Brackets	10 ea. 3/8-16 Nyloc Nuts
2 ea. 3" round U-Bolts	10 ea. 3/8" Flat Washers

Note: Some drilling will be required.

Instructions:

1. Assemble the sway bar pivot bushings over the sway bar.
2. Using the U-bolts and saddle brackets, loosely attach the sway bar to the axle. Depending on the leaf spring location, the brackets will be directly over, or under the axle. Trucks that have the leaf springs mounted over axle will have the sway bar mounted on the top of the axle

Stock Suspension Shown:

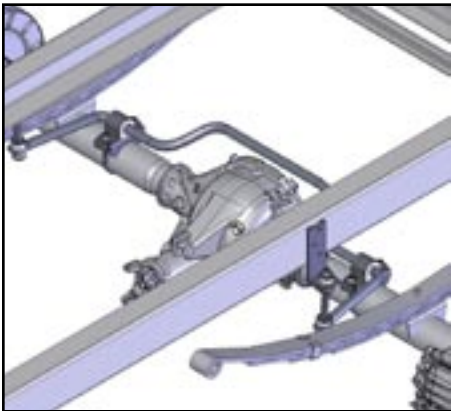

Trucks that have the leaf springs mounted under the axle will have the sway bar mounted under the axle.

Flipped Springs Shown:

3. Position the saddle brackets as far apart as possible. Adjust the brackets so that the sway bar is centered under the frame. Tighten the U-bolts that secure the sway bar pivot bushings.

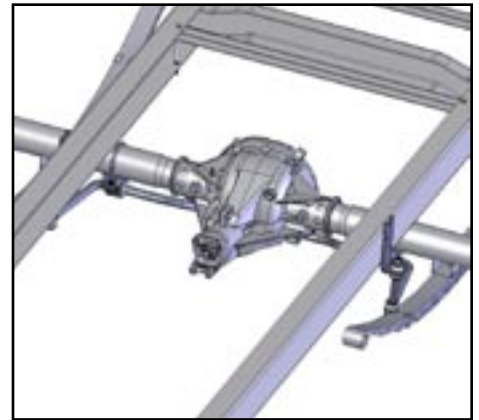

4. Install the end links thru the ends of the sway bar and the end link brackets. 1947-1954 GM trucks will use the flat end link brackets; all others should use the 90° end link brackets.
5. Rotate the sway bar so that the two forward legs are parallel to the ground at ride height.

Note: It may be necessary to turn the 90° end link bracket over due to the differences in spring manufactures, sagged springs, lowered springs, etc. The diagram shows the two different directions the bracket can be mounted.



6. Using the sway bar end links as a template, mark and drill the 6 3/8" holes that will be used to mount the end link brackets.
7. Bolt the end link brackets to the frame.

For technical help call Classic Performance Products Monday thru Friday 8:30am to 5:00pm at (714) 522-2000.

Classic Performance Products, Inc. 714.522.2000 | fax 714.522.2500

175 E. Freedom Avenue | Anaheim, CA 92801 | www.classicperform.com