



# Specialty Power Windows

## WINDSHIELD WIPER KIT INSTALLATION INSTRUCTIONS

---

**\*\*\*IMPORTANT\*\*\***  
**READ CAREFULLY**

**READ THE INSTRUCTION BOOK CAREFULLY** before trying to assemble and install your Windshield Wiper Kit. Should you encounter any difficulty in the installation and or operation of your unit, please re-read the instructions and watch the shop installation video.

---

1. Determine where you will mount the wiper transmissions. They require 3/8-inch holes either through the cowl or through the area above the windshield. If no holes exist, mark and drill them so both transmissions are in the same position relative to the windshield sweep area. For example, if the right transmission sweeps 120 degrees, the left will also sweep 120 degrees. Consider where the wipers will park as well.

Some original equipment transmissions housings and trim bezels may be used by gutting OEM housing and drilling the housing out to 3/8 inch. With the old housing modified, remount it in the original position using the bezel and retainer. The new transmission will be installed **THROUGH** the old unit. Take time to study your old parts to make sure this conversion will work.

Some applications require modification to the cowl and installation of the included 5/8" O.D. X 3/4" long spacers. These are usually positioned where over-sized OEM transmissions are removed. Tack-weld the 5/8" O.D. X 3/4" long spacers in place at the proper angle (90° off the windshield and square to the glass) and equal at height. Fill any voids with sheet metal and weld solidly. Finish any required bodywork before continuing.

2. After determining which wiper transmission mounting position to use (up or down according to the illustrations on page 5A & 5B), mount wiper arm transmissions from the inside. Check for interference with other equipment, and adjust the threaded housing height accordingly.

With the transmissions in place, mark the threaded housing if they need to be cut just above the outer retaining nut. Remove the transmission and **DISASSEMBLE IT BEFORE CUTTING IT, INCLUDING THE INNER SHAFT**. The inner shaft is removed by loosening the set screw in the knurled pivot and removing the transmission back plate. Run one of the retainer nuts over the housing before cutting, and deburr the cut.

Replace the shaft in the housing and slide the knurled pivot down to its new position. Mark the shaft just above the pivot, remove the shaft and cut it. **GREASE** gear and shaft liberally with wheel bearing grease. Reassemble the transmission and reinstall it.

3. Pre-bend, mark, cut, and flare both ends of a length of tubing to fit between the two transmissions. Tube flares fit in notches in the back plate of the transmissions (see diagram length "B"). Leave 4 inches of straight tubing from all ends for smooth operation later. Use SINGLE FLARES in all cases as double flares may leave a ridge which will cause noisy wiper operation.

4. Cut and flare both ends of a 4-inch piece of the cut-off tube if possible or from the remaining tube if not. This is tubing length "A" in the diagram. The extra flare may prevent a noise problem.

5. Install tubes "A" and "B." MAKE SURE FLARES ARE FIT INTO NOTCHES. DO NOT CRUSH FLARED TUBE ENDS.

6. Assemble the motor, spacer washer, and three retaining bolts according to the illustration on page 4. The motor can be rotated into any position on the housing.

7. Choose the mounting location for the motor assembly, making sure to avoid obstructions, and limiting the distance from the closest transmission to 36" (the length of the aluminum tube if not cut in step #4). THE TOTAL LENGTH OF THE THREE REQUIRED TUBES MUSTS NOT EXCEED 72." Pre-fit the motor assembly so the next measurement can be made accurately (we recommend that you mount motor housing so you can service wiper unit with just removing the cover.)

8. Measure for tubing LENGTH "C" from the transmission notch to the notch in the nylon block in the motor gear housing as per illustration. It is often best to pre-bend the tube to fit, and then mark, cut, and flare both ends. NOTE THAT THE MAXIMUM BEND RADIUS IS 3" (see illustration pg 5).

9. Slide the cable into the tube housings, through both transmissions, until the block at the end of the cable is against the motor end of tube "C." Mark the cable where it protrudes from the end of tube "A." Remove the cable from the housing and cut it off at this mark. Deburr the cut so it will slide back in place easily. COAT the cable HEAVILY with wheel bearing grease and reinstall it in the housing.

10. Determine the sweep angle of your wiper system. This is the total angle in degrees that the wiper arm travels from its PARK position to the POINT OF MAXIMUM TRAVEL. The drive wheel is drilled in increments of 10 degrees from 90 to 160 degrees (see illustration pg 5). Mark the hole in the drive wheel corresponding to the sweep angle.

11. Run the motor to determine the park position. At this time it pays to run the switch and motor through all positions to make sure everything is connected properly, and all functions are correct. The motor is a coast to park motor. **When not under load it may coast through the park position and continue to run.** If this happens, attach the drive wheel to the motor and apply pressure with your hand. The motor should park in the same position each time. You may also connect the drive link and cable if the unit is installed. This should result in consistent parking.

12. Determine the X or Y park position from the illustration pg 5A and 5B, and install the drive wheel on the motor shaft in the correct position. The hole you chose in step #10 will be on the CENTER LINE of the guide block (see illustration pg 4A) either as close to the block (X parking position), or as far from the block (Y parking position) as possible (see illustration pg 5A or 5B). If you make an error, the motor will not park the wiper arms correctly, and you will have to re-position the drive wheel. If you make an error determining the sweep angle, the drive wheel must also be re-positioned for the new parking position corresponding to the drive wheel hole used. If you choose the wrong parking position, the wipers will park at the maximum travel point.

13. Locate the cable and cable housing in the motor assembly. Install the drive link into the correct hole in the drive wheel and the hole in the cable end block. GREASE all moving parts liberally with wheel bearing grease. Replace the motor gear housing cover and mount the motor assembly (if not already mounted). Make sure all tube housings are in the notches and that all hardware is snug.

**DO NOT INSTALL WIPER ARMS UNTIL THE SYSTEM IS COMPLETE AND HAS BEEN CHECKED FOR PROPER OPERATION. INSTALL ONE ARM AT A TIME, CHECKING FOR OPERATION.**

14. Mount the switch in a convenient place and connect the wiring according to the diagram. Make sure both units are grounded well. The wiper unit will not work properly without a good ground.

15. Using the switch, run the motor to make certain that everything is functioning correctly. Note that the parking position is correct, and that the sweep angle is correct (we test sweep angle and park first with a pair of wire ties to represent the wiper arms.)

16. If noise is evidenced, look first to see if a flare is not properly seated in its notch. Other common noise sources are where the cable is too long, where the last short tube ("A") is missing, tube "A" is too short, or tube "A" is not flared on both ends. Insufficient grease may also make the unit noisy.

17. Install one wiper arm at a time with the system in park position and the arm installed accordingly. Wet the glass with water or with a glass cleaner before operating the wipers. Have a helper turn on the switch and check each arm for travel and park position. Be ready to lift the arm off the glass or away from the body to avoid damage. When one works, repeat the procedure with the other to complete the installation.

18. Wiper transmission shafts will accommodate both 1/2-inch fine-splined knurled wiper arms (with knurled pivot installed) and arms designed for 1/4-inch shaft with set screw (knurled pivot not installed.) Some aftermarket arms are cast with too few splines to adequately engage with the fine splined pivot and will tend to strip. (Suitable replacement wiper arms are available through Specialty Power Windows.)

**\*\*\*IMPORTANT\*\*\***

**WE CANNOT ACCEPT THE RETURN ON ANY PRODUCT WITHOUT A RETURN GOODS AUTHORIZATION ISSUED BY US. CONTACT OUR TECH HELP / WARRANTY DEPARTMENT AT 478-994-9248 1:30-4:30 PM EASTERN.**

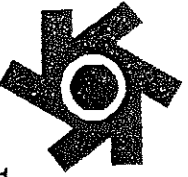

# SPECIALTY POWER WINDOWS

## WIPER MOTOR INSTALLATION

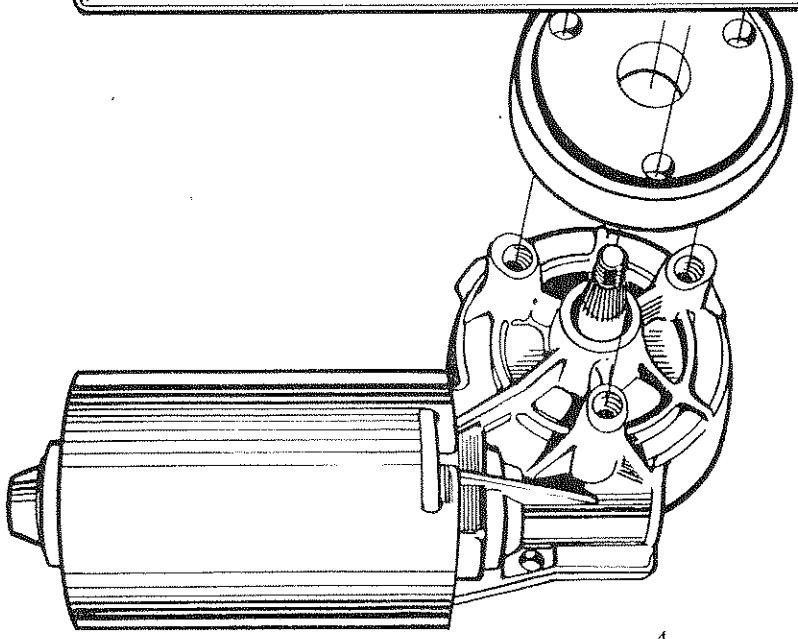
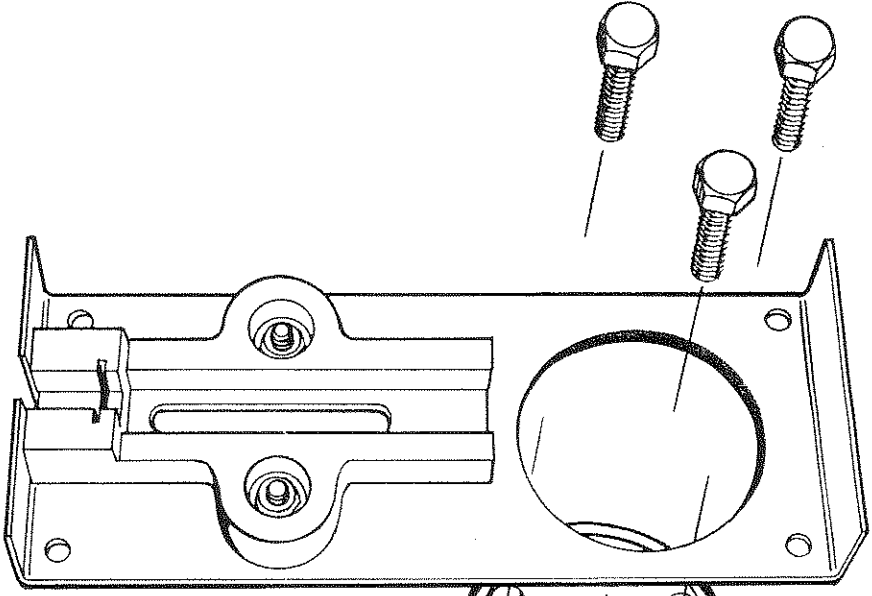
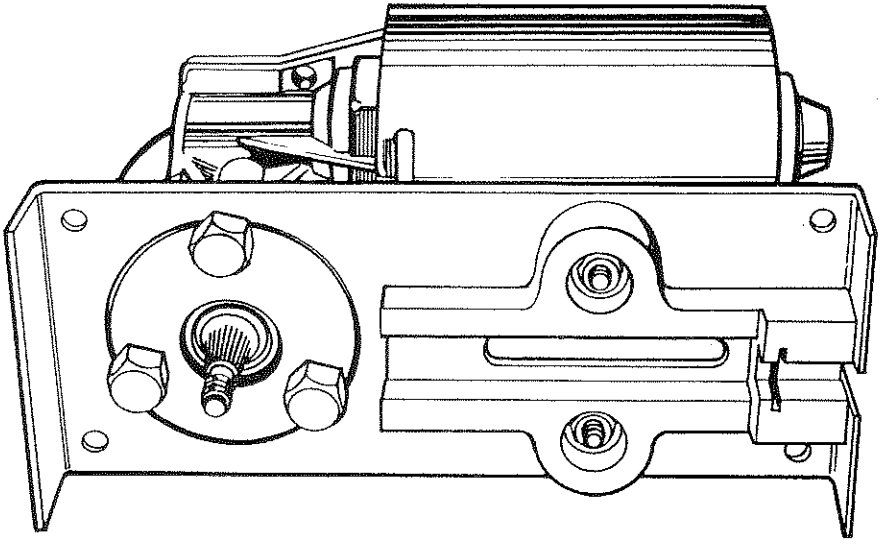

MOTOR MUST BE IN PARK POSITION BEFORE SETTING SWEEP.

FOR THE WIPERS TO PARK AT THE END OF THE STROKE,  
THE LINK MUST BE STRAIGHT IN LINE WITH SLIDER ON THE  
WIPER CABLE. ALSO YOU MUST PLACE THE DRIVE WHEEL  
WITH THE SWEEP HOLE YOU SELECT, STRAIGHT IN LINE WITH  
THE DRIVE CABLE AND LINK.

THE COVER MUST BE RE-INSTALLED ON THE GEAR HOUSING BEFORE EACH TEST

INCORRECT

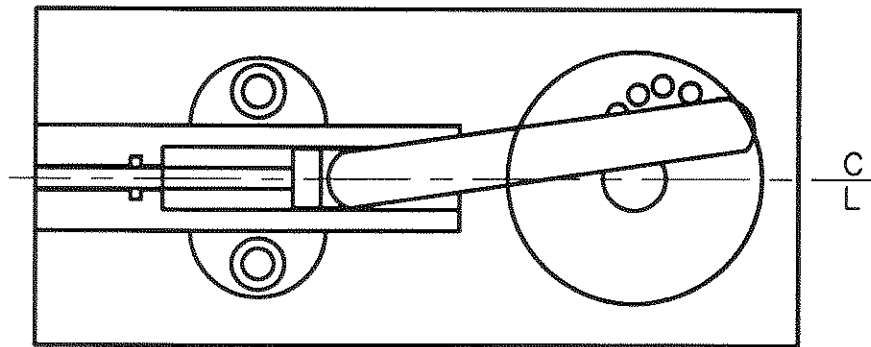

INCORRECT

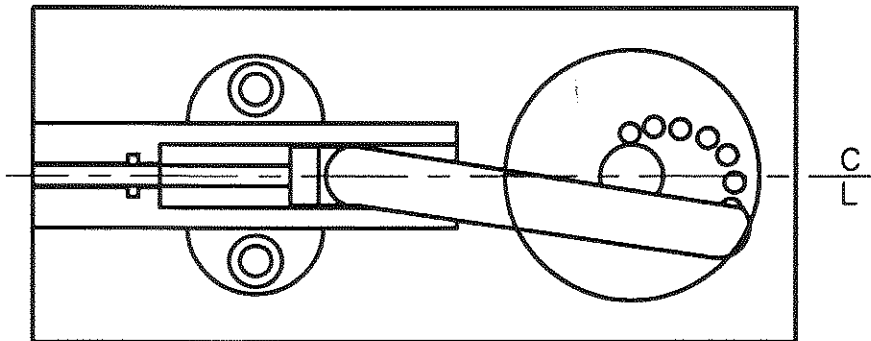

CORRECT

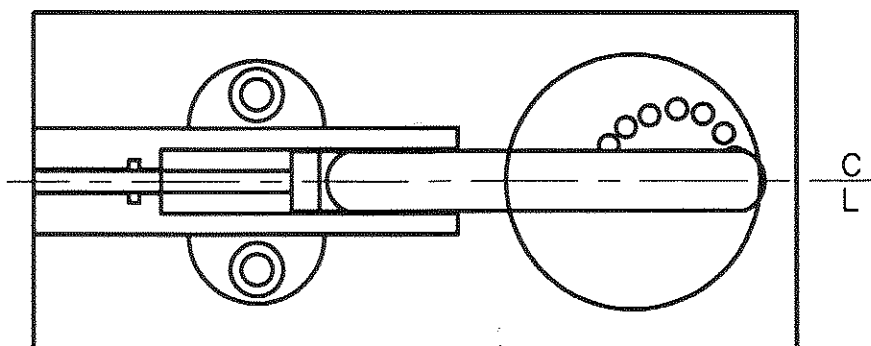

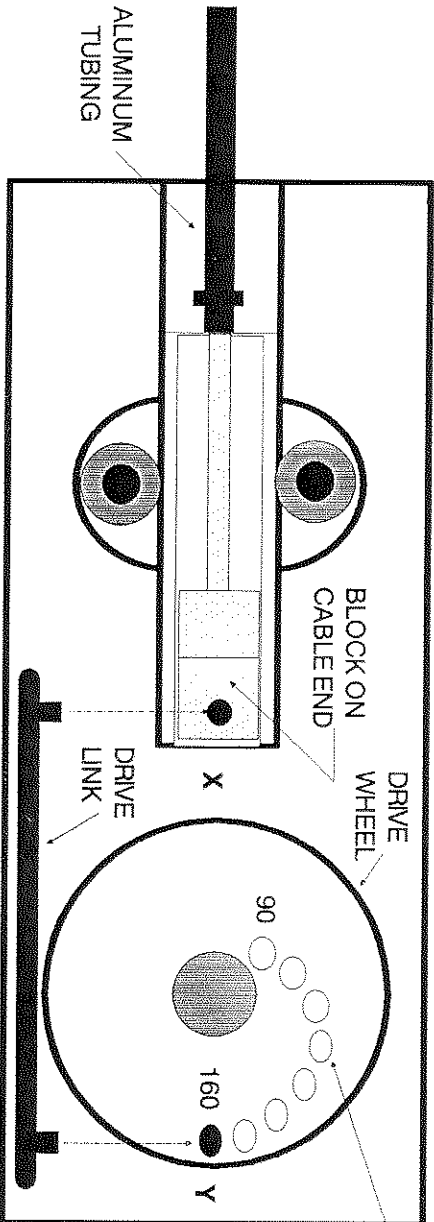
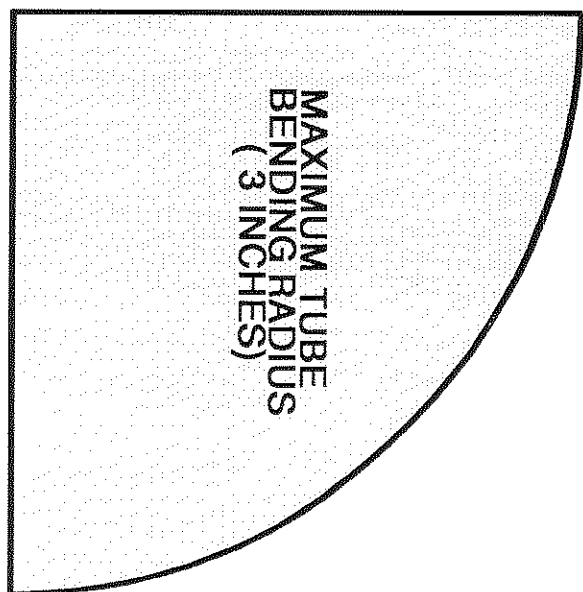
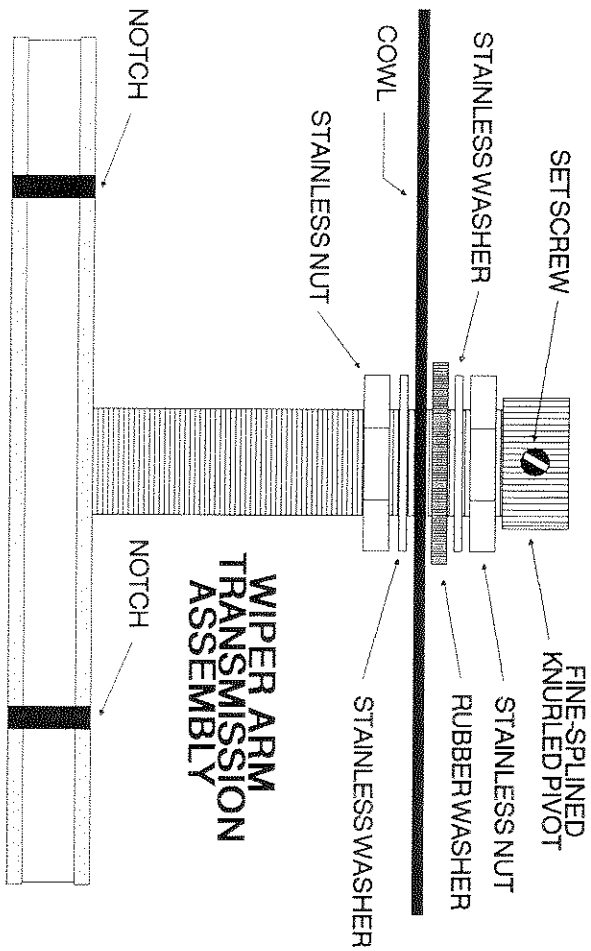
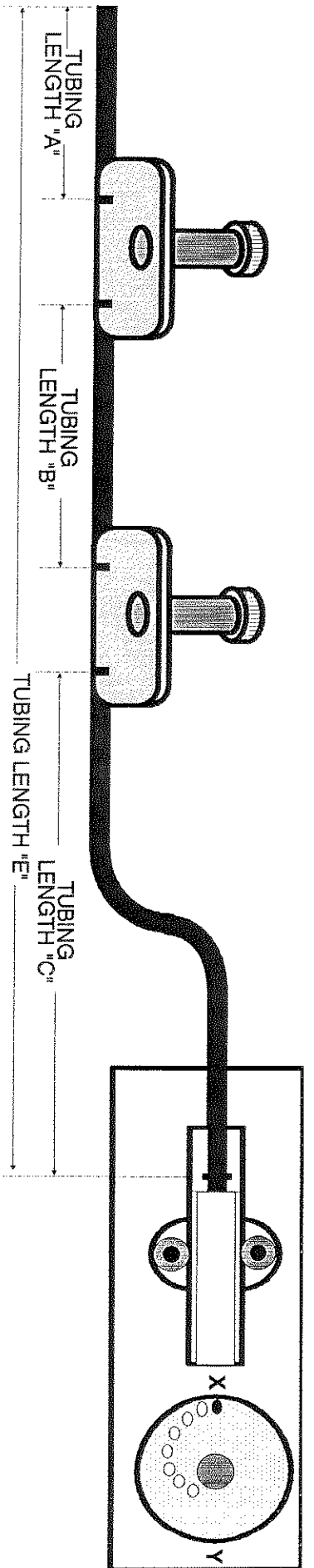

HOLES AT 10  
DEGREE INTERVALS  
FROM 90 TO 160 DEGREES  
TOTAL SWEEP

**MOTOR GEAR HOUSING  
ASSEMBLY**

**SPECIALTY POWER WINDOWS**

