



Steering, Brake & Suspension Specialists

#4856DBK-5.5 - Disc Brake Conversion Instructions for 1948-56 Ford F-100 (5 on 5.5" Bolt Circle)

Parts List:

ROTORS:

73-93 F-100/F-150 (or Ford equivalent)

CALIPERS:

71-87 GM 1/2 Ton Truck (or GM equivalent)

BEARINGS & SEALS:

A2 Outer Bearings

A13 Inner Bearings

4148 Bearing Seals

MOUNTING HARDWARE

Notes:

On some applications it may be necessary to drill the lower spindle holes from 7/16" to 1/2".

Read these instructions completely before attempting this conversion

BEFORE BEGINNING INSTALLATION, MAKE SURE YOUR WHEELS FIT ON THE DISC ROTOR. This kit only works with 15" and up wheels due to the 11 3/4" rotors.

Make sure this kit fits your application before painting or plating. Parts that have been painted, plated or modified may not be returned.

Instructions:

1. Remove the drum and backing plate assemblies from the stock spindles. Inspect the bearing surfaces on the spindle. If the spindle is grooved, a piece of 180-grit emery cloth can be used to clean it up.
2. Install the bearing adapters onto the spindles. *Note: If the bearing adapter can spin on the axle shaft, you can install the adapter with a small amount of red Loctite.*

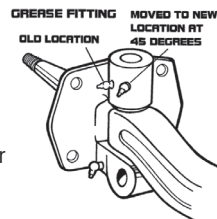

3. The zerk grease fitting needs to be moved to clear the bracket as shown in the diagram. Remove the zerk fitting and bolt on the caliper bracket. Mark a location on the spindle where the zerk fitting will clear the caliper bracket, typically, it is about 45 degrees further back than the original location. Remove the caliper brackets and re-insert the zerk fitting in the original location. Drill a hole in the marked location with a no. 3 drill (.2130) Don't worry! The king pin is case hardened, you won't damage it. Once the hole is drilled, tap the hole with a 1/4-28 NF tap. To clear the debris from the new location, pump grease through the zerk fitting at the stock location until you are

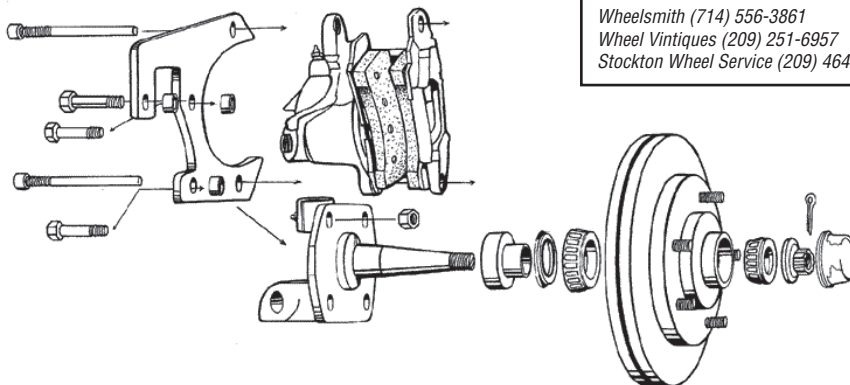

confident it is clean. Move the zerk fitting to the new location and plug the old zerk hole with the supplied 1/4-28 set screw.

4. Install the caliper mounting bracket onto the backside of the spindle. Make sure the caliper opening is pointing towards the rear of the truck. The spacers provided in the kit go between the bracket and spindle. When attaching the caliper bracket to the spindle be sure that the nuts are on the inside of the rotor. Also, the flat of the nut must be up against the shoulder of the spindle in order for the nut to seat correctly. This is very important.
5. Slide the caliper onto the bracket with the bleeder up. The caliper may not slide into place due to a bump in the casting next to the piston bore. In some cases, it will be necessary to grind this bump flush using a bench grinder. Reinstall the caliper and turn the spindle full lock left and right to check for any interference. The caliper bracket should clear the king pin locknut. If not, reverse the king pin nut so that it is on the front side of the axle.
6. Remove caliper from bracket.
7. If you purchased your rotors from someone other than CPP, remove stock inner race from the rotors and replace them with the races supplied in the A2 bearing sets. Pack all of the bearings with grease, and install the inner bearings and seals into the rotors.
8. Install the rotors onto the spindle first then install the outer bearings, spindle washer, spindle nut spacer, and the spindle nut. Adjust the wheel bearing clearance, install the cotter pin and dust cap.
9. Install the calipers with the bleed screws up.
10. Double check that all of the bolts are tight and proceed to bleed the brake system.

Warning:

Stock drum brake wheels may not work with disc brake conversions. Drum brake wheels were not made with disc brakes in mind so there may be wheel to caliper clearance problems. Before installing this kit, make sure your wheels fit the brake assembly.

For those wanting to keep stock wheels that interfere with the installation, there are companies such as Wheelsmith, Stockton Wheel Co. and Wheel Vintiques that can remove the original wheel centers and re-install them into a new disc brake rim. Please call for more information.

Wheelsmith (714) 556-3861
Wheel Vintiques (209) 251-6957
Stockton Wheel Service (209) 464-7771

GENERAL TORQUE SPECIFICATIONS:

1/4"	grade 5	10lb/ft	1/4"	grade 8	14lb/ft
5/16"	grade 5	19lb/ft	5/16"	grade 8	29lb/ft
3/8"	grade 5	33lb/ft	3/8"	grade 8	47lb/ft
7/16"	grade 5	54lb/ft	7/16"	grade 8	78lb/ft
1/2"	grade 5	78lb/ft	1/2"	grade 8	119lb/ft
9/16"	grade 5	114lb/ft	9/16"	grade 8	169lb/ft
5/8"	grade 5	154lb/ft	5/8"	grade 8	230lb/ft

For technical help call Classic Performance Products Monday thru Friday 8:30am to 5:00pm at (714) 522-2000.

Classic Performance Products, Inc. 714.522.2000 | fax 714.522.2500

175 E. Freedom Avenue | Anaheim, CA 92801 | www.classicperform.com